

THIS DRAWING IS UNPUBLISHED. RELEASED FOR PUBLICATION, 19
 © COPYRIGHT 19 BY AMP INCORPORATED, HARRISBURG, PA. ALL INTERNATIONAL RIGHTS RESERVED. AMP PRODUCTS MAY BE COVERED BY U.S. AND FOREIGN PATENTS AND/OR PATENTS PENDING.

| REVISIONS | | | | | | |
|-----------|---|------|-----|----------------------------------|---------|----------|
| P | F | ZONE | LTR | DESCRIPTION | DATE | APPROVED |
| ✓ | ✓ | | D | REDRAWN & REVISED PER ECN R-1451 | 9-25-85 | PER SJB |
| ✓ | ✓ | | E | OBSOLETE -3, -4, & 1-0 1R-2760 | 3-4-87 | SJB |
| | | | F | REV PER 063D-269-03 CT | 5-03 | ONE |

ASSIST SPRING
 MATL: STAINLESS STEEL
 PER G.Q.-S-766

TERMINAL LATCH
 MATL: NYLON
 COLOR: (SEE TABLE)

CONTACT BODY
 MATL: COPPER PER G.Q.-C-576
 FINISH: (SEE TABLE)

AMP & WIRE SIZE STAMPED
 ON INSULATION BARREL

POINT OF PLATING
 MEASUREMENT

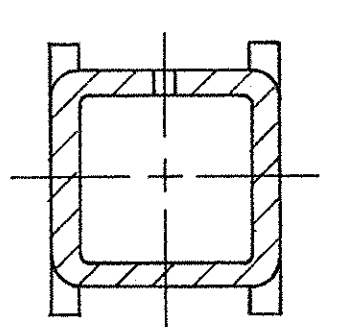
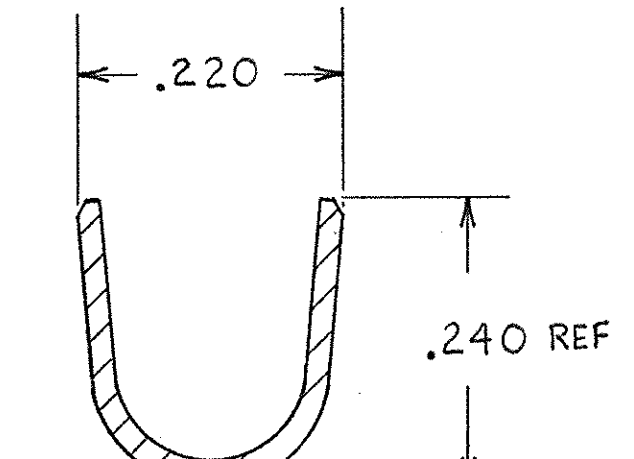
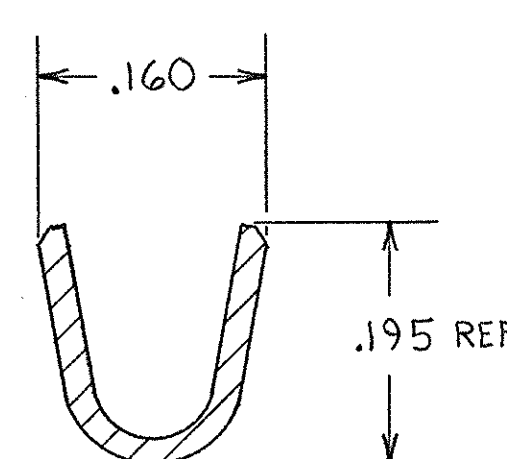
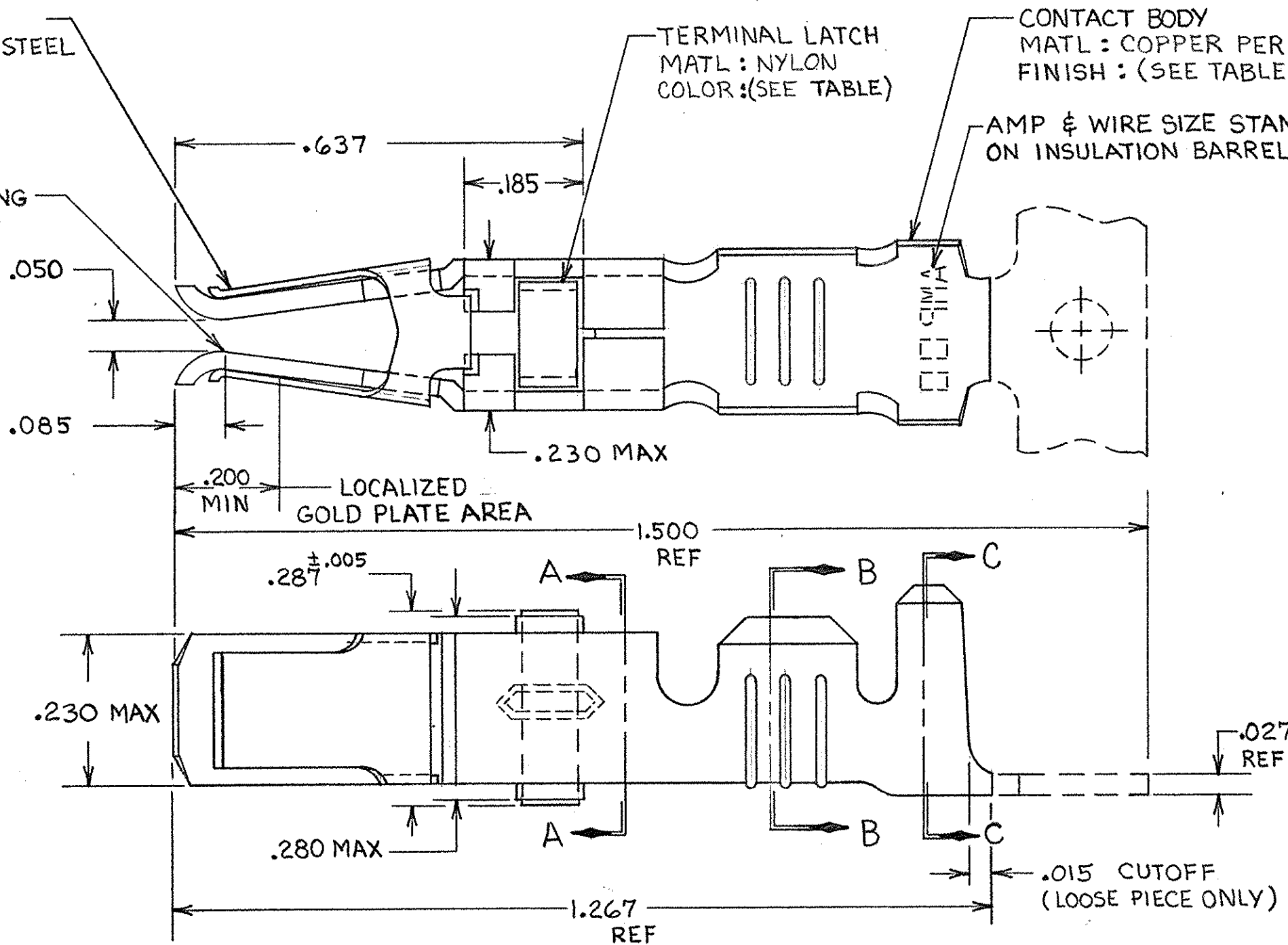

- 1 REELED FOR USE WITH STANDARD APPLICATORS.
- 2 REELED FOR USE WITH HEAVY DUTY MINI-APPLICATORS.
- 3 PLATED WITH .000100 MIN SILVER PER G.Q.-S-365.
- 4 PLATED WITH .000015 MIN GOLD PER MIL-G-45204 IN THE LOCALIZED GOLD PLATE AREA, GOLD FLASH ON THE REMAINDER, OVER .000030 MIN NICKEL PER G.Q.-N-290.
- 5 PLATED WITH .000030 MIN GOLD PER MIL-G-45204 IN THE LOCALIZED GOLD PLATE AREA, GOLD FLASH ON THE REMAINDER, OVER .000030 MIN NICKEL PER G.Q.-N-290.
- 6 PLATED WITH .000050 MIN 93-7% TIN-LEAD ALLOY OVER .000030 MIN NICKEL PER G.Q.-N-290.
- 7. WIRE RANGE = 12-16 AWG.
- 8. INSULATION RANGE = .140-.165 DIA.

9 PLATED TIN (NO LEAD). 0.00050 MIN THK PER ASTM-B-595 OVER NICKEL .000030 MIN THK PER QQ-N-290.

| | | | |
|---------|----|---------------------|-------------|
| BLACK | 1 | 2-66740-1 | 2-66740-0/2 |
| BLACK | 2 | 2-66740-1 | 1-66740-9 |
| BLACK | 3 | 66740-8 | 1-66740-2 |
| BLACK | 4 | 66740-6 | 1-66740-1 |
| BLACK | 5 | OBSOLETE | 1-66740-0 |
| NATURAL | 6 | 66740-2 | 66740-9 |
| BLACK | 7 | 66740-8 | 66740-7 |
| BLACK | 8 | 66740-6 | 66740-5 |
| BLACK | 9 | OBSOLETE | 66740-3 |
| NATURAL | 10 | 66740-2 | 66740-1 |

| | | | | |
|--|-------------|-------------|--|------------|
| UNLESS OTHERWISE SPECIFIED DIMENSIONS ARE IN INCHES. TOLERANCES ON: DECIMALS ±.010 ANGLES ±.010 | CONTRACT NO | | AMP INCORPORATED Harrisburg, Pa. 17105 | |
| | DR | 9-25-85 | | |
| | MATERIAL | SEE CALLOUT | NAME | |
| | FINISH | SEE DASH NO | FEMALE TYPE XII CONTACT ASSEMBLY, WITH ASSIST SPRING | |
| OTHER APPD | | SIZE | FSCM NO | DRAWING NO |
| | | C | 00779 | 66740 |
| SCALE NTS | | | SHEET | |